

2017 East Coast Albacore Championship

SAILING INSTRUCTIONS

1 RULES

- 1.1* The regatta will be governed by the 'rules' as defined in *The Racing Rules of Sailing (RRS 2017-2020)*.
- 1.2 The prescriptions of Sail Canada may also apply.
- 1.3 The Albacore class rules will also apply and will override the RRS 2017-2020 if there is a conflict. If there is a conflict between these sailing instructions and the RRS 2017-2020 then these sailing instructions will take precedence.

2 SAFETY

- 2.1 Every competing boat must carry the required safety equipment as prescribed by transport Canada's Safe Boating Guide, including the following specific items:
- An approved life jacket or P.F.D. for each sailor. Life jackets must be worn at all times while racing.
 - A bailing device.
 - A 10 metre tow rope
 - A sound signaling device (ie: whistle)
 - A paddle

Boats without this minimum equipment will not be permitted to compete.

- 2.2 Each boat is required to sign-out prior to leaving the dock and sign in within 30 minutes of returning to shore. Failure to comply will result in disqualification from the day's races.
- 2.3 A boat that retires from a race shall notify the race committee as soon as possible.

3 NOTICES TO COMPETITORS

Notices to competitors will be posted on the official notice board(s) located at the covered lower deck at the Shelburne Harbour Yacht Club.

4 CHANGES TO SAILING INSTRUCTIONS

Any change to the sailing instructions will be posted before 09:30 on the day it will take effect.

5 SIGNALS MADE ASHORE

- 5.1 Signals made ashore will be displayed at the flag pole located on the upper deck of the Shelburne Yacht Club.
- 5.2 When flag AP is displayed ashore, the following race will start no less than 45 minutes after the flag is lowered.

5.3 Rule 40 applies at all times while afloat.

6 SCHEDULE OF RACES

6.1 Racing is scheduled as follows:

Date

2016-08-18	18:00	shakedown race(s)
2016-08-19	11:00	first warning signal; others to follow (lunch on the water)
2016-08-20	10:30	first warning signal; others to follow (lunch on the water)
	17:00	awards presentation

6.2 When more than one race will be held on the same day, the warning signal for each succeeding race will be made as soon as is practical.

6.3 No warning signal will be made after 16:00 on 2017-08-19 .

6.4 No warning signal will be made after 14:30 on 2017-08-20.

7 CLASS FLAG

The class flag will be a white flag bearing the blue Albacore class insignia.

8 RACING AREAS

8.1 Racing will take place in the open waters of Shelburne Harbour approximately 2 km south of Shelburne Marina.

8.2 Course examples may be posted on the Official Notice Board located in the covered lower deck area of the Shelburne Harbour Yacht Club.

9 MARKS

9.1 Marks 1 and 3 will normally be yellow cylinders. Mark 2 on a triangle and olympic course will normally be a yellow cylinder.

9.2 When a change of course occurs during racing the new mark(s) shall be of a contrasting colour or shape. See section 11.

9.3 The starting and finishing marks will be orange spherical marks or code flag “M”.

10 THE START

10.1 Races will be started by using rule 26 with the warning signal given 5 minutes before the starting signal.

10.2 The starting line will be between the mast flying a white flag with the letters “R C” on the race committee boat and an orange round mark, or code flag M. See section 9.3.

- 10.3 The “Round-the-ends” rule for starts will be in effect at all times even though code flag “I” may not be flown. This changes rule 30.1.
- 10.4 A boat starting later than 5 minutes after her starting signal will be scored Did Not Start. This changes rule A4.1.
- 10.5 The race committee may apply rule 30.2 (Z-flag Rule, 20% penalty), 30.3 (U-flag rule), or 30.4 (Black-Flag Rule) at its discretion.
- 10.6 In the event of a number of unidentified premature starters, the Race Committee will signal a General Recall by raising the First Substitute pennant and making two sound signals. If there is a general recall, a new warning signal will be made (raise class flag with sound signal) approximately one minute after the general recall is lowered and the starting sequence will continue from that point.

11 CHANGE OF THE POSITION OF THE NEXT MARK

- 11.1 To change the position of the next mark, the race committee will lay a new mark (or move the finishing line) and remove the original mark as soon as practicable. The change will be signalled before the leading boat has begun the leg, although the new mark may not yet be in position. Any mark to be rounded after rounding the new mark may be relocated without further signalling to maintain the course configuration. When in a subsequent change a new mark is replaced, it will be replaced by an original mark.
- 11.3 Boats shall pass between the race committee boat signalling the change of course and the nearby mark, leaving the mark to port and the race committee boat to starboard. This changes rule 28.1.

12 THE FINISH

- 12.1 The finishing line will be between a white flag with the letters “RC” flying from a mast on the race committee boat (not necessarily the starting boat) and an orange spherical mark or code flag “M”. See section 9.3.
- 12.2 On the finishing leg of any course, mark 3 (refer to course diagrams) may be passed on either side.

13 PROTESTS AND REQUESTS FOR REDRESS

- 13.1 Protest forms are available from the race committee. Protests shall be delivered there within the protest time limit.
- 13.2 The protest time limit is 30 minutes after the race committee boat signals its arrival on shore.
- 13.4 Notices of protests by the race committee or protest committee will be posted to inform boats under rule 61.1(b).

14 SCORING

- 14.1 The Low Point scoring system of Appendix A-4 will apply.
- 14.2 1 (one) race is required to be completed to constitute a series.

- 14.3** (a) When three or fewer races have been completed, a boat's series score will be the total of her race scores.
- (b) When four or more races have been completed, a boat's series score will be the total of her race scores excluding her worst score.
- (c) When six or more races have been completed, a boat's series score will be the total of her race scores excluding her two worst scores.
- (d) Black flag disqualifications shall not be discarded from a boat's total series score.

15 REPLACEMENT OF CREW OR EQUIPMENT

- 15.1** Substitution of competitors will not be allowed without prior approval of the race committee.
- 15.2** Substitution of damaged or lost equipment will not be allowed unless approved by the race committee. Requests for substitution shall be made to the committee at the first reasonable opportunity.

16 EQUIPMENT AND MEASUREMENT CHECKS

- 16.1** A boat or equipment may be inspected at any time for compliance with the class rules and sailing instructions.
- 16.2** All boats shall have a valid buoyancy endorsement.
- 16.3** All boats shall have a valid measurement certificate.
- 16.4** All sail numbers must match their respective hull numbers unless prior authorization has been granted by the regatta chair and the race committee. See RRS 2013-2016 Appendix G3.

17 RADIO COMMUNICATIONS AND ELECTRONICS

- 17.1** A boat shall neither make radio transmissions while racing nor receive radio communications not available to all boats. This restriction also applies to mobile telephones.
- 17.2** Boats may carry position recording devices enabled by the global positioning system (GPS) provided that any such device does not communicate any position data to the sailor while afloat. This includes time between races. This changes International Albacore Class Rule C.5.1(a)

18 PRIZES

18.1 Prizes will be given as follows:

Championship Series: Top three finishing boats overall in the Championship Fleet will receive skipper and crew awards.

18.2 Youth Series: The top boat helmed by a youth under 19 years of age will receive a skipper and crew award.

18.3 Navy League: The top “Navy League” boat will be given a skipper and crew award.

18.4 Female Sailor Award: To the top non-placing female sailor.

18.5 Under 12: Highest placed under 12 helm.

18.6 Any other categories as decided by the awards committee.

19 DISCLAIMER OF LIABILITY

Competitors participate in the regatta entirely at their own risk. See rule 4, Decision to Race. The organizing authority will not accept any liability for material damage or personal injury or death sustained in conjunction with or prior to, during, or after the regatta.

Addendum – Illustrating the Courses

**A Windward-Leeward-Triangle (Olympic) Course
Signalled by flying Code Flag “O” or by displaying an information card
showing the letter “O” on the committee boat**

1 – 2 – 3 – 1 - (Finish)

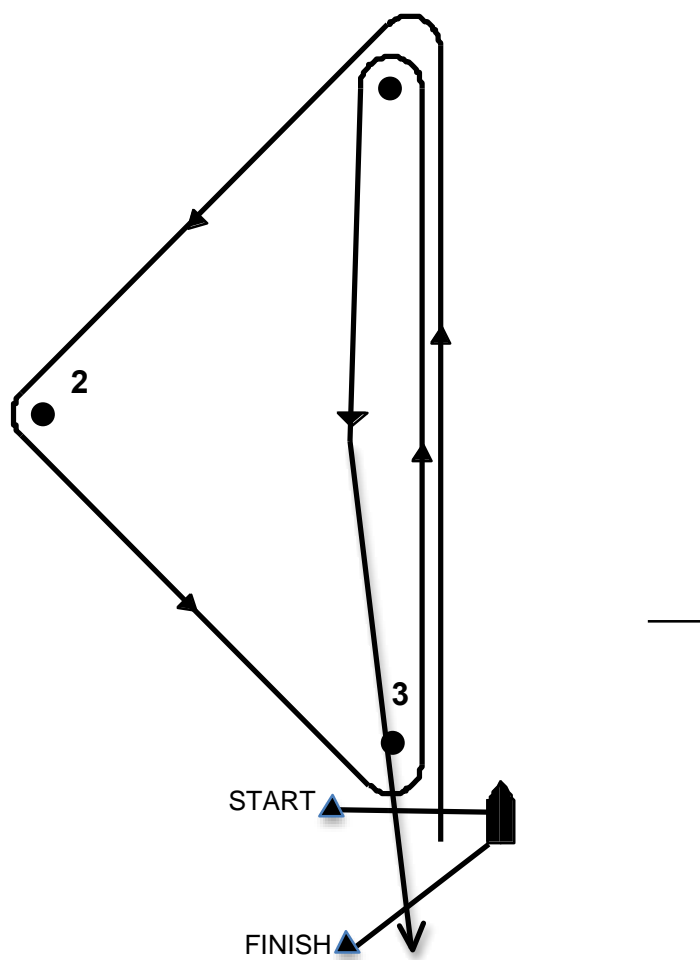

A Triangle Course
Signalled by flying Code Flag “T” or by displaying an information card
showing the letter “T” on the committee boat

1 – 2 – 3 – 1 – 2 – (Finish)

